

VW322

per pompa OMFB

VOLKSWAGEN Crafter 2,0 CDI

Dal 2017 – motore 1968 cc – 4 cilindri – con A/C – trazione anteriore e 4x4

From 2017 – engine 1968 cc – 4 cylinders – with A/C – FWD and 4x4

Istruzioni di montaggio kit innesto elettromagnetico

Electromagnetic coupling kit installation instructions

- Sollevare il veicolo utilizzando un adeguato ponte sollevatore
- *Raise the vehicle by using a suitable lift bridge*

<u>TABELLA GENERALE DI SERRAGGIO BULLONI (Nm)</u>							
<u>GENERAL TABLE OF TIGHTENING BOLTS (Nm)</u>							
Qualità Quality	M6	M7	M8	M10	M12	M14	M16
8,8	10,3	17,1	25,5	50	87	138	210
10,9	14,7	24,5	35,3	70	122	194	299
12,09	17,6	28,4	42,1	85	147	235	358

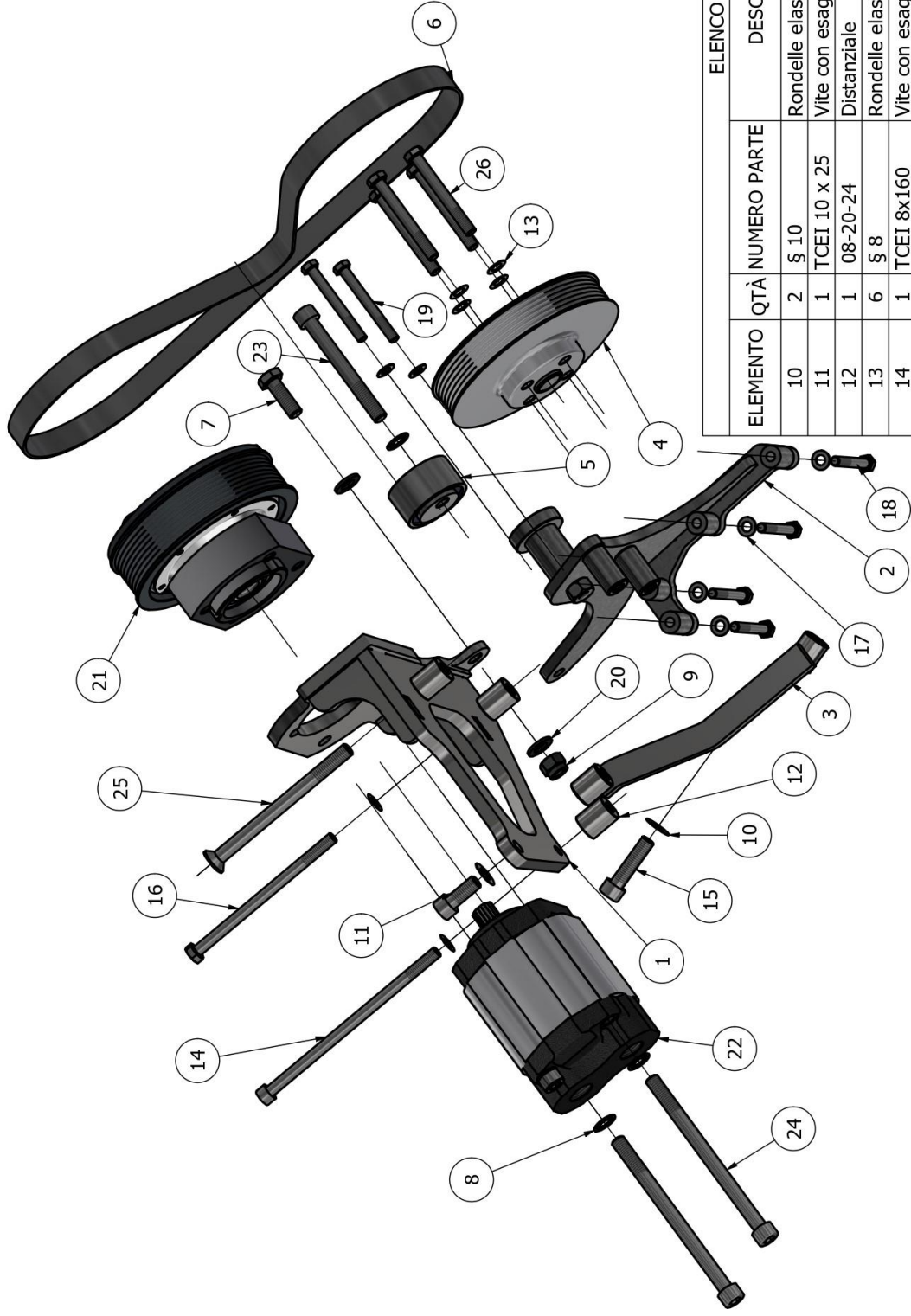

ELENCO PARTI

ELEMENTO	QTÀ	NUMERO PARTE	DESCRIZIONE	Description
10	2	§ 10	Rondelle elastiche	Spring washers
11	1	TCEI 10 x 25	Vite con esagono incassato	Screw with hexagon socket
12	1	08-20-24	Distanziale	Spacer
13	6	§ 8	Rondelle elastiche	Spring washers
14	1	TCEI 8x160	Vite con esagono incassato	Screw with hexagon socket
15	1	TCEI 10 x 40	Vite con esagono incassato	Screw with hexagon socket
16	1	TE 8 x 130	Vite a testa esagonale	Screw head hexagonal
17	6	§ 7	Rondelle elastiche	Sporing washer
18	4	TE 7 x 50	Viti a testa esagonale	Screws head hexagonal
19	2	TE 7 x 65	Viti a testa esagonale	Screws head hexagonal
20	2	§ 10	Rondelle piane	Flat washers
21	1	001361	Innesto elettromagnetico	Electromagnetic clutch
22	1	Pompa	Pompa con raccordi posteriori	Pump with rear fittings
23	1	TCEI 10 x 90	Vite con esagono incassato	Screw with hexagon socket
24	2	TCEI 10 x 140	Viti con esagono incassato	Screws with hexagon socket
25	1	TCEI 10x130	Vite con esagono incassato	Screw with hexagon socket
26	4	TE 8 x 75	Viti a testa esagonale	Screws with hexagon socket

ELENCO PARTI

ELEMENTO	QTÀ	NUMERO PARTE	DESCRIZIONE	Description
1	1	VW21731	Staffa	Bracket
2	1	VW21731	Staffa ausiliaria	Auxiliary bracket
3	1	VW21736	Staffa posteriore	Rear bracket
4	1	VWP008	Puleggia motore	Motor pulley
5	1	PG1014	Puleggia tendicinghia	Belt tensioner pulley
6	1	6PK1190	Cinghia	Belt
7	1	TE 10 x 30	Vite a testa esagonale	Screw head hexagonal
8	3	§ 10	Rondelle zigrinate	Knurled washers
9	1	M10	Dado autobloccante	Self-blocking dice

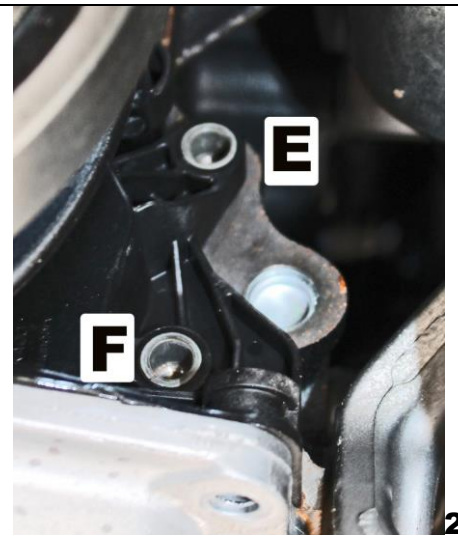
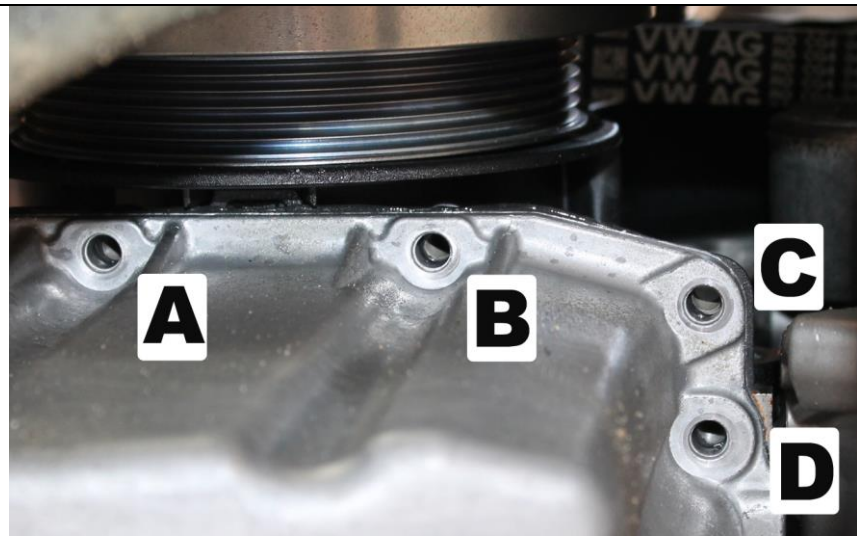

- Eliminare le viti **A B C D E F**
- Allentare la cinghia del motore
- Smontare la puleggia del motore , ed eliminare le viti di fissaggio
- *Eliminate the screws **A B C D E F***
- *Loosen the engine belt*
- *Disassemble the engine pulley, and eliminate the fixing screws*

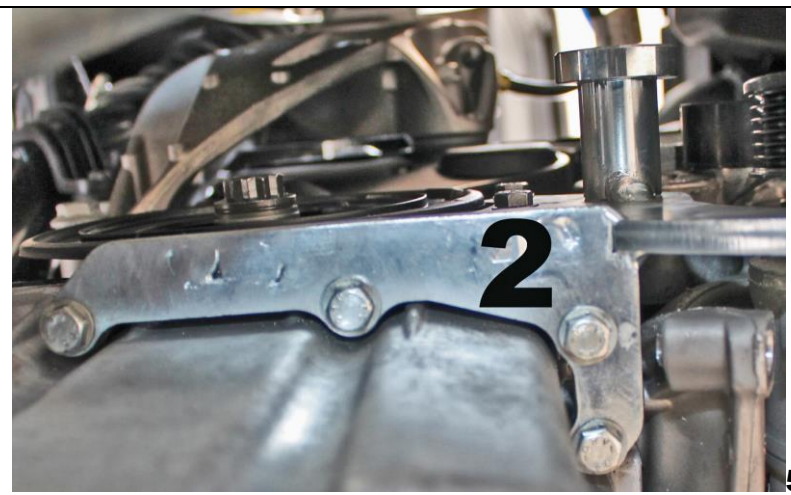

- Utilizzando la bulloneria fornita fissare la staffa **2** nei fori filettati **A B C D E F**
- Rimontare la puleggia del motore , sovrapporre la puleggia fornita e fissare con la bulloneria fornita
- *By using the supplied screws, fix the bracket **2** in the threaded holes **A B C D E F***
- *Reassemble the motor pulley, overlap the supplied pulley and fasten with the supplied screws*

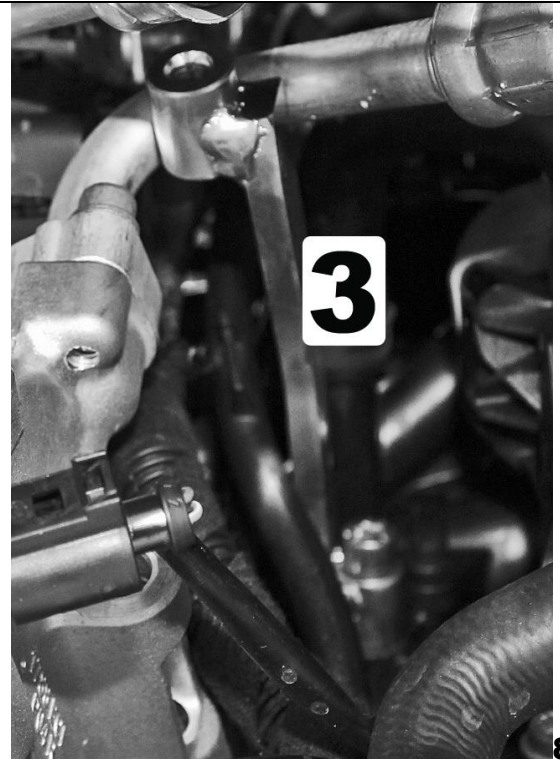
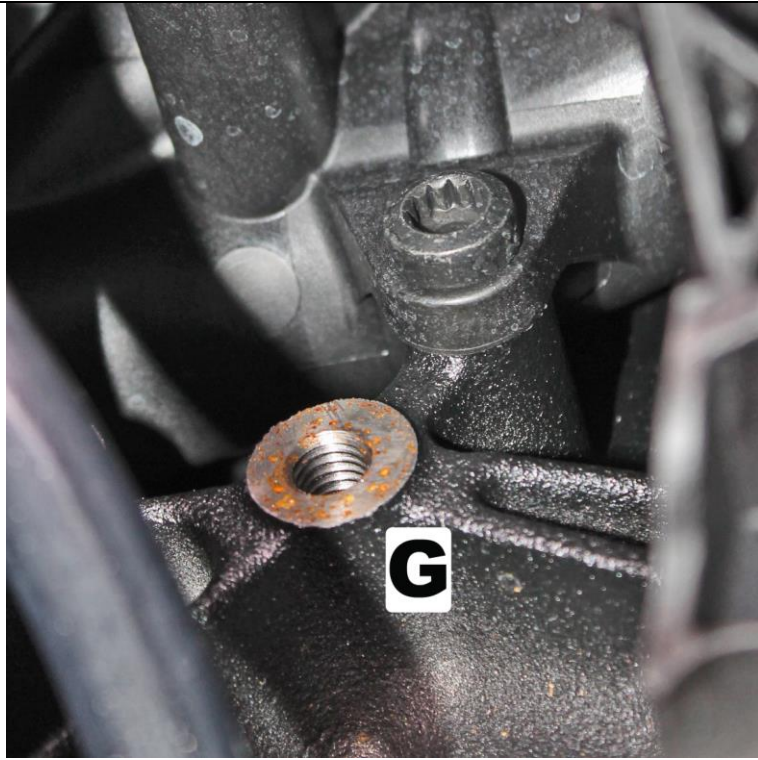

- Installare la staffa **3** nel foro filettato **G** , senza , al momento stringere vite
- *Install the bracket **3** in the threaded hole **G** , without at the moment , tightening the screw*

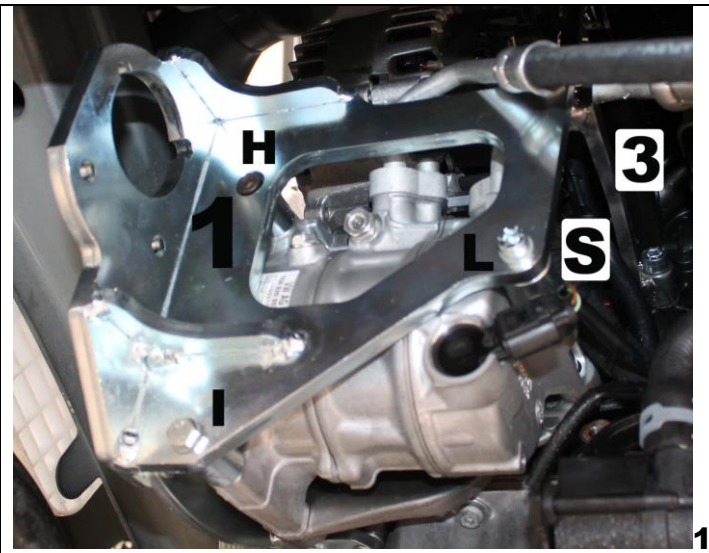
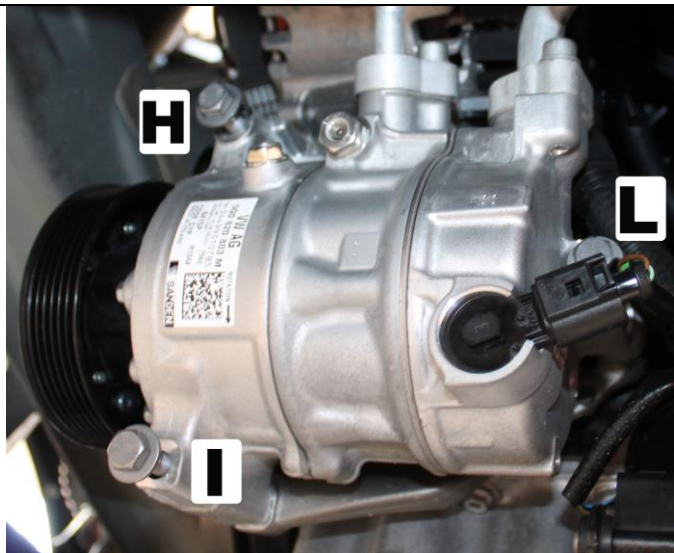

- Eliminare le viti di fissaggio , **H I L** . del compressore aria condizionata
- Al loro posto , utilizzando la bulloneria fornita , fissare la staffa **1** , inserire il distanziale **S** , fornito , nel punto **L**
- *Remove the fixing screws , **H I L** , of the air conditioning compressor*
- *In their place, using the supplied screws, fix the bracket **1** and insert the spacer **S** in the **L** point*

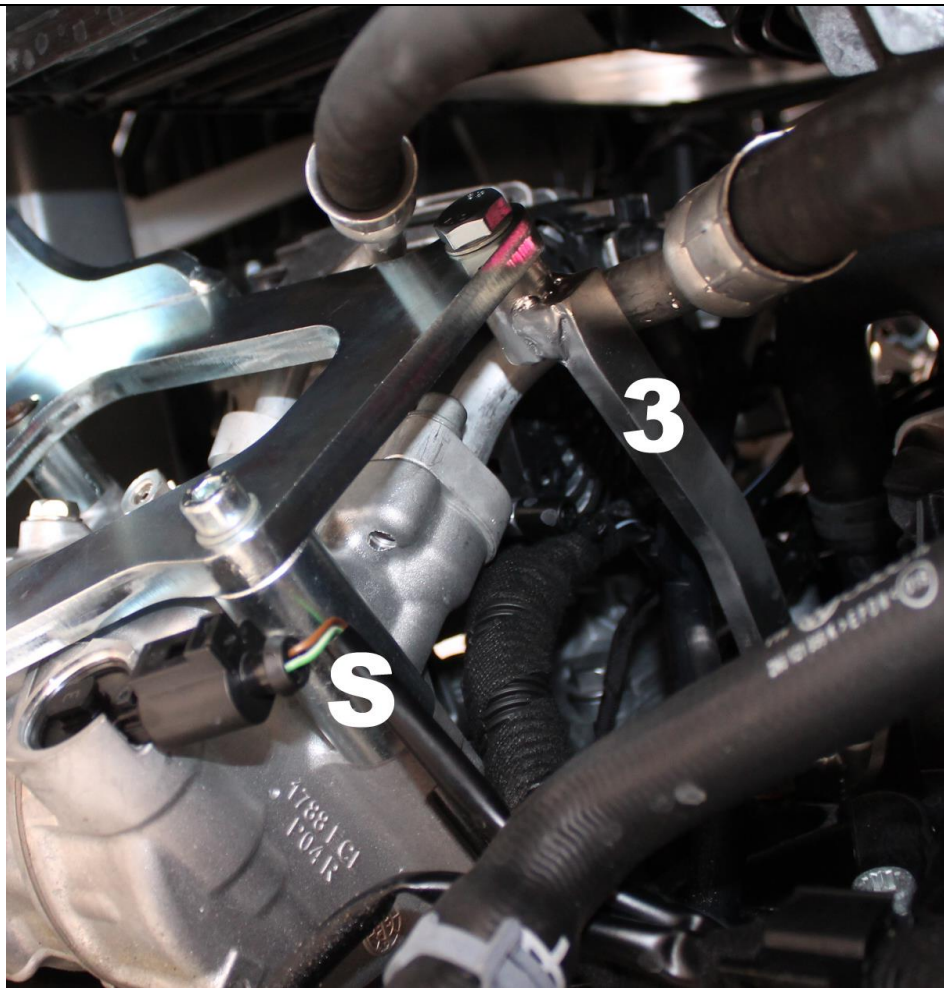

11

- Fissare la staffa 1 alla staffa 3
- Nel punto M fissare la staffa 1 alla staffa 2
- Poi stringere tutte le viti e i bulloni

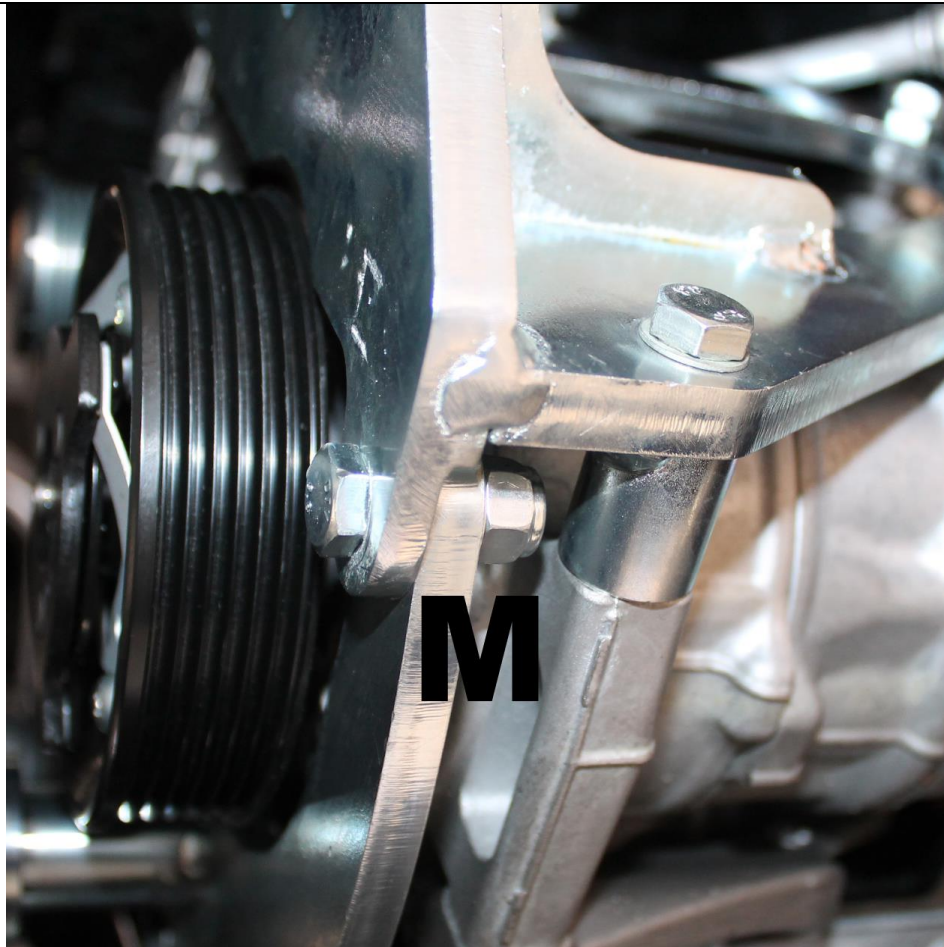

12

- *Fix the bracket 1 to the bracket 3*
- *At point M, fasten bracket 1 to bracket 2*
- *Then tighten all the screws and the bolts*

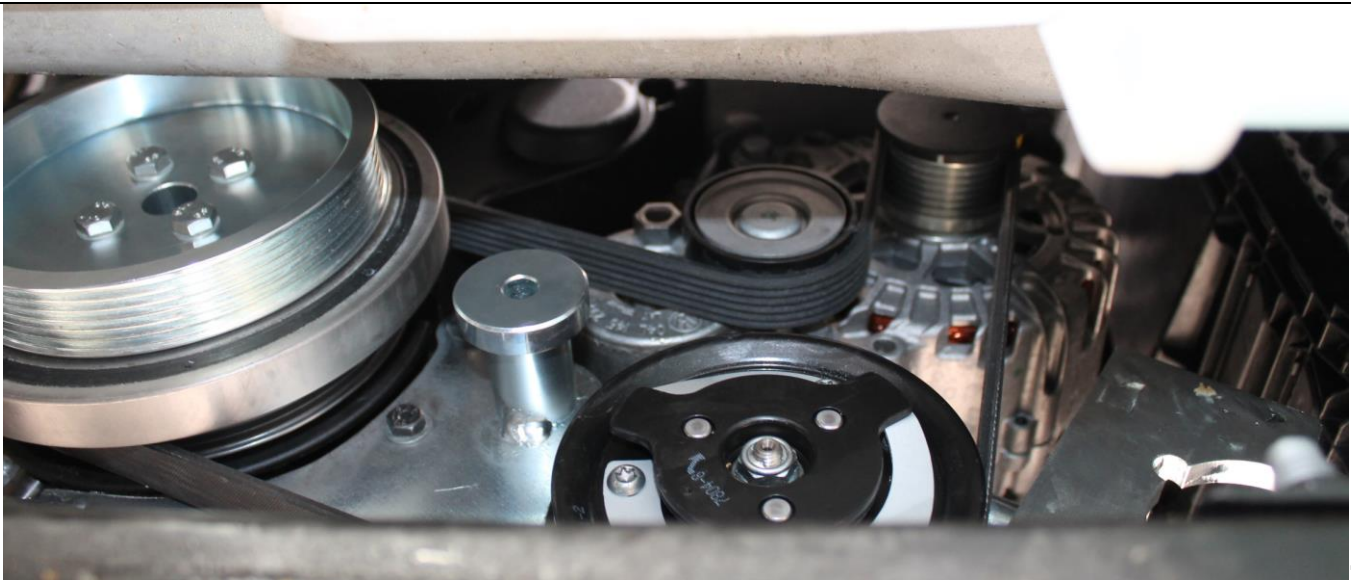

13

- Riposizionare la cinghia del motore
- *Reposition the engine belt*

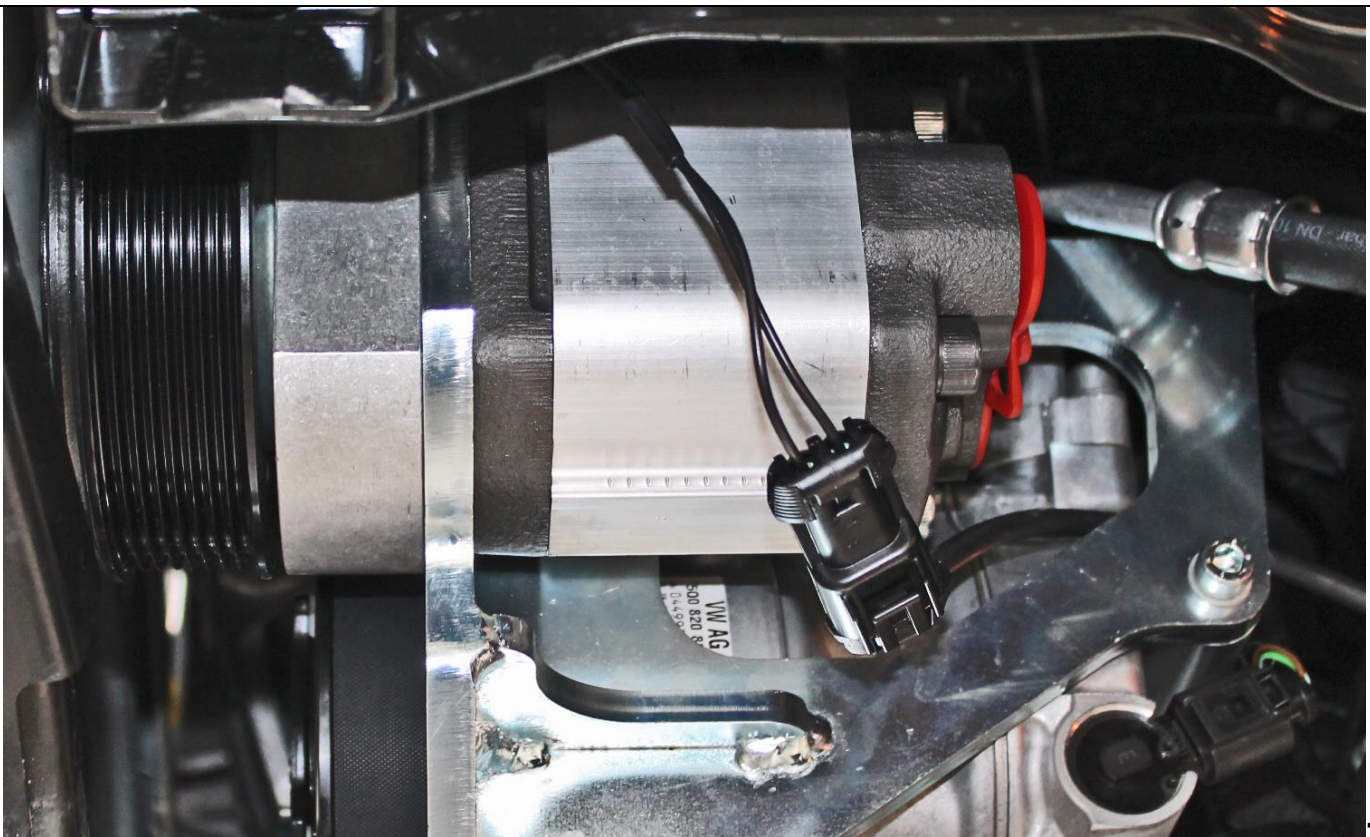

14

- Installare la frizione elettromagnetica e la pompa
- *Install the electromagnetic clutch and the pump*

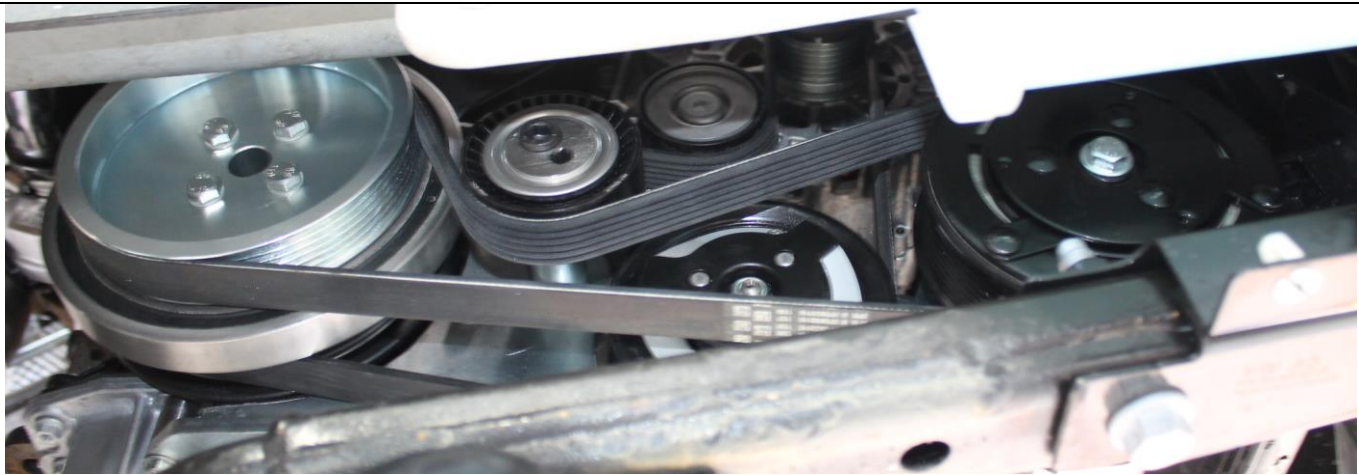

15

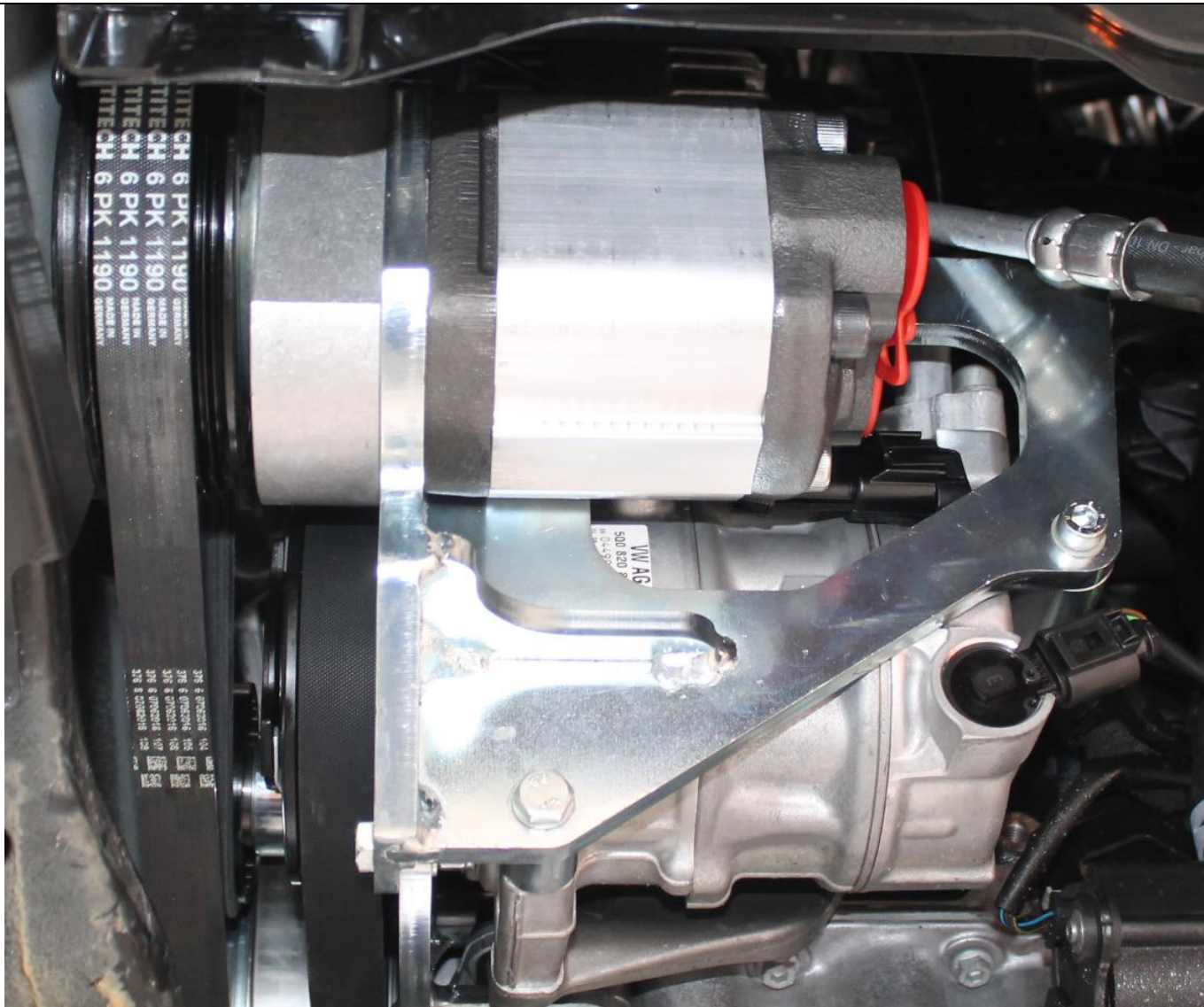

16

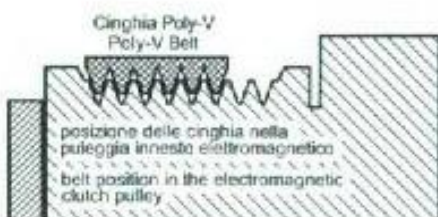

17

- Installare la cinghia e la puleggia tendicinghia
- Regolare la tensione delle cinghia
- *Install the belt and the belt tensioner pulley*
- *Adjust the belt tension*